

MBRP

AT-9526PT

MUFFLER ASSEMBLY, 5"

2011-UP POLARIS SPORTSMAN TOURING 850

2017-UP POLARIS SPORTSMAN TOURING XP 1000

2011-2014 POLARIS SPORTSMAN TOURING 550, SPORTSMAN X2 550

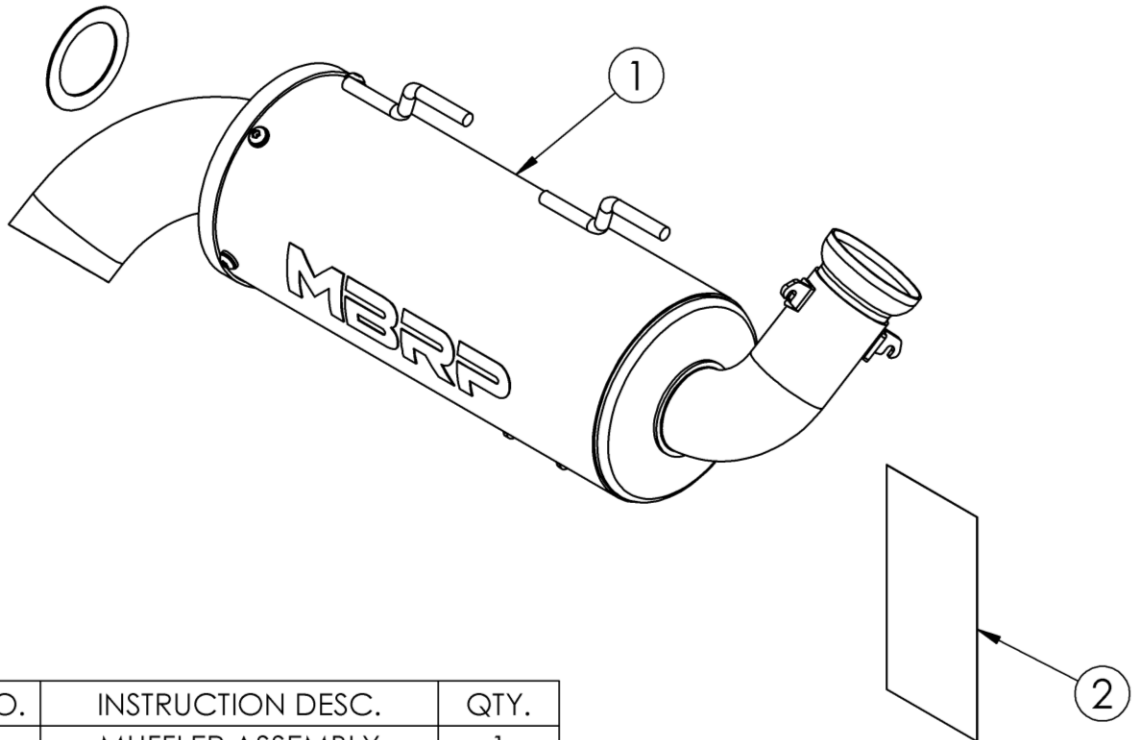

ITEM NO.	INSTRUCTION DESC.	QTY.
1	MUFFLER ASSEMBLY	1
2	FOIL TAPE	1
3	RING INSERT	1

PLEASE READ BEFORE STARTING INSTALLATION

While MBRP Ltd. has made every effort to ensure that all components of this system are of superior quality and properly packaged, it is the installer's responsibility to ensure the following before removal of the factory exhaust:

- that ALL components shown above are present.
- that ALL mating components fit together.
- that there are no damaged components.
- that the system you have purchased is appropriate for your vehicle year, model and configuration.
- that the system will not interfere with any modifications previously installed or planned.
- that you have read and understand these instructions.

If you have any questions or are uncertain about any aspect of the installation of this system to your vehicle please contact your dealer before commencing installation.

MBRP

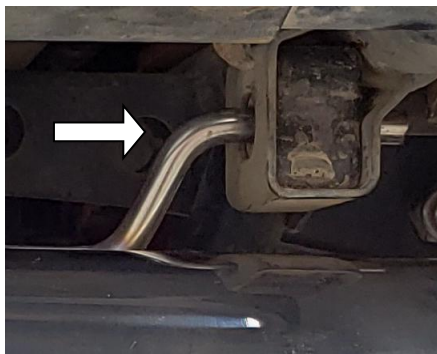

Figure 1

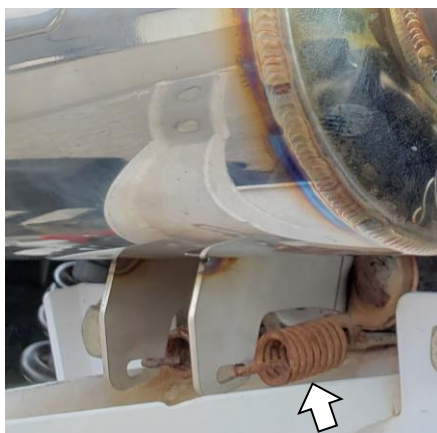

Figure 2



Figure 3



Figure 4

Removal of Stock Exhaust:

1. Remove the two (2) springs securing the muffer inlet.
2. Remove the two (2) springs from the lower muffer mount.
3. Slide the muffer hangers out of the rubber isolators to remove the muffer. Retain the gasket on the front pipe, as it will be reused.

Installation of MBRP Exhaust:

1. Slide the hangers of the new **Muffer Assembly** into the rubber isolator mounts. Refer to Figure 1.
2. Ensure that the gasket is in place on the outlet of the front pipe.
3. Place the bottom bracket of the **Muffer Assembly** over the center locator and secure it into position by installing the two stock springs onto the bracket, then install the remaining (2) springs onto the muffer inlet. Refer to Figures 2 and 3.
4. Use the supplied **Foil Tape** to protect the exposed plastic on the underside of the rear deck, between the muffer hangers. Refer to Figure 4.

It is recommended that the muffer screws be retightened after the first ride and checked periodically thereafter, tightening if necessary.

Note: This muffer utilizes a quiet insert (pre-installed) to limit sound levels. If increased exhaust flow is desired, replace the quiet insert with the **Ring Insert** by removing the muffer tip and the spark arrestor. Reinstall the spark arrestor with the **Ring Insert**. Note that tuning may be required for optimal performance with the increase in flow capacity.

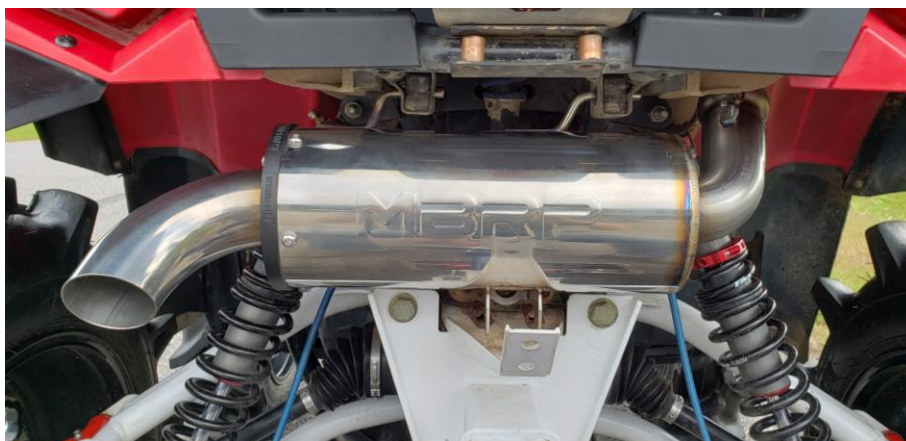

Congratulations! You are ready to begin experiencing the improved performance and driving excitement of your MBRP ATV Exhaust upgrade. We know you will enjoy your purchase.



Figure 1



Figure 2



Figure 3



Figure 4

Spark Arrestor Maintenance

In order to maintain optimal performance, the spark arrestor screen should be cleaned after the first 3 hours of use. Afterwards clean every 30-35 hours of use.

Clean-out Instructions:

Make sure the vehicle is cool before completing the clean-out procedure.

1. Using a 4mm hex key, remove the 4 screws securing the outlet cap or tip. **(Figure 1)**
2. Remove the outlet cap to expose the spark arrestor screen insert. **(Figure 2)**
3. Remove the screen insert. **(Figure 3)**
4. Using a wire brush, thoroughly brush the screen to remove residue. **(Figure 4)**
5. Replace the screen and cap.
6. Tighten the screws to 60 in-lbs (6.8 Nm).